

All dimensions are in inches

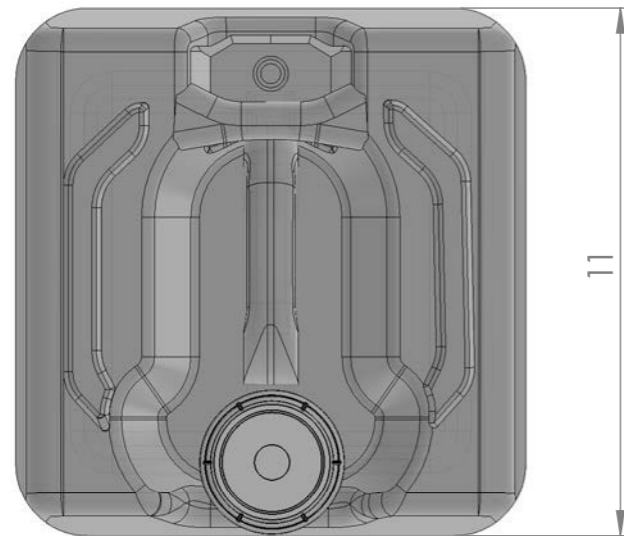

- **Physical Specifications:**
 - Container Detail:
 - Container Quantity: 1ea. 5.5 Gallon Pail
 - Product Weight (Containers and Fluid): 1ea. 50.1 lbs
 - Fluid Volume per Container: 5.5 Gallons
 - Fluid Density at 68F: 8.5957 lbs/gal
 - Weight per Container (Without Fluid): 2.8 lbs
 - Dimensions: 1ea. 11"L x 11"W x 14.98"H
 - Shipping Detail:
 - Shipping Dimensions: 1ea. 12"L x 12"W x 16"H
 - Shipping Weight (Including Packaging and/or Pallet): 1ea. 52 lbs
- **Fluid Content Details:**
 - Total Fluid Volume of Product: 5.5 Gallons
 - Glycol Content: Greater than 95% by volume
 - Guaranteed Assay (Purity) of Propylene Glycol: Greater Than 99.8% (USP Certified)
 - Proprietary Corrosion Inhibition Mixture: Approximately 5% by volume
- **Physical Properties:**
 - Acceptable Temperature Range: -50F (-46C) to 250F (121C)
 - Boiling Point: 360.2F / 182.3C
 - Freezing Point: -70.3F / -56.8C
 - Specific Gravity @ 60F/15C: 1.06
 - Specific Heat @ 60F: 0.6 BTU/lbF
 - Viscosity @ 60F: 45.9 cP
 - Appearance: Clear/Colorless as standard (can upgrade with dyed blue option)
- **Chiller Glycol™ DF1** is typically diluted with water in order to form any of the below concentrations.

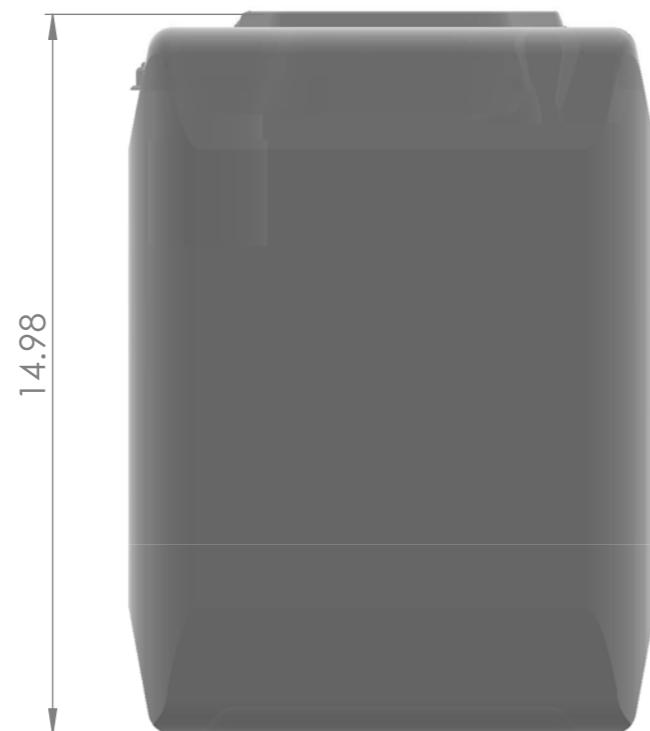
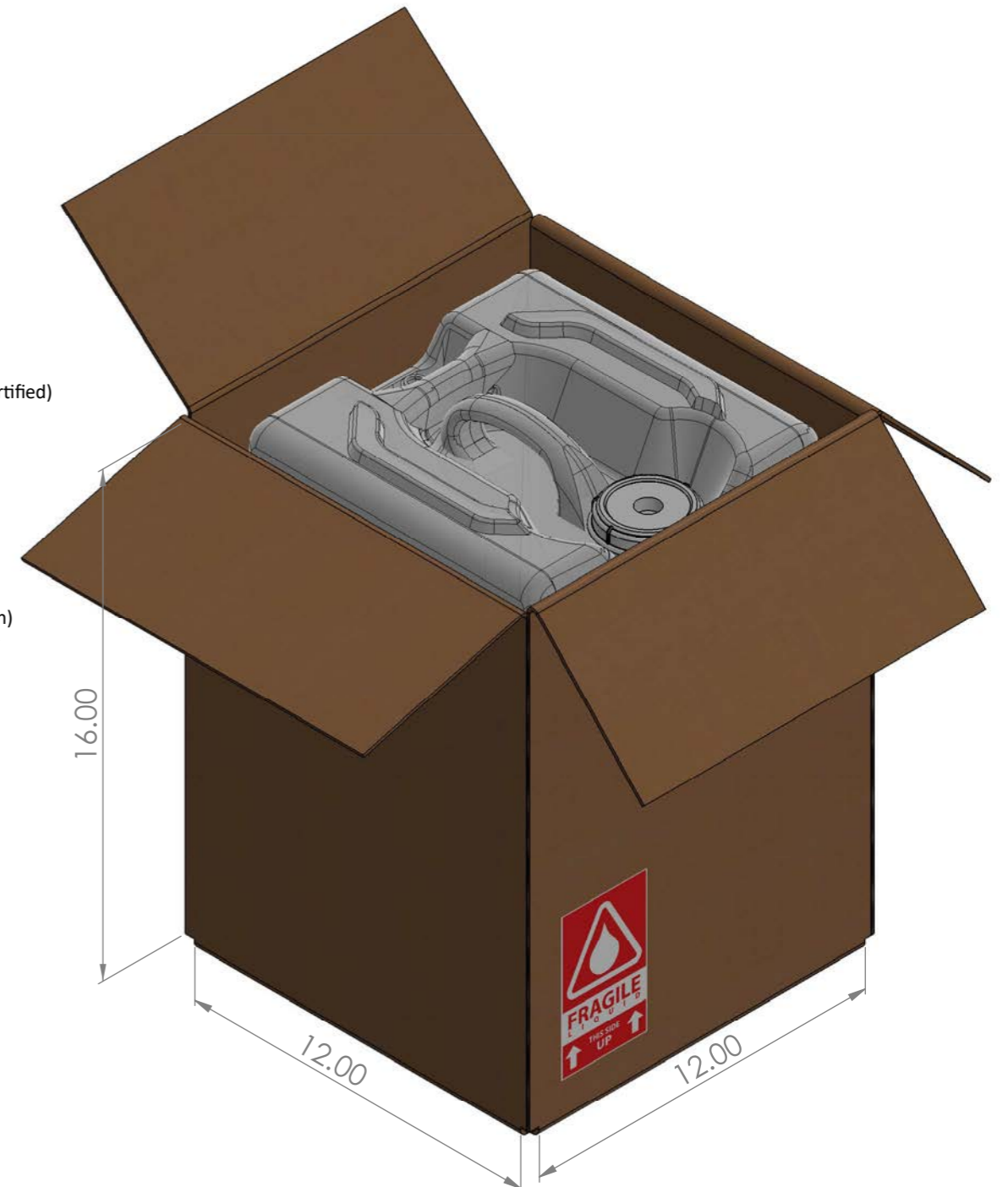

Sales: 8951 Synergy Drive, Suite #224, McKinney, TX 75070
 Fulfillment: 526 Charlotte Ave, Bldg #1, Burkburnett, TX 76354
 1-855-GLYCOLS sales@glycol.com

UNLESS OTHERWISE SPECIFIED: DIMENSIONS ARE IN MILLIMETERS		FINISH:		DEBURR AND BREAK SHARP EDGES		DO NOT SCALE DRAWING		REVISION	
SURFACE FINISH:									
TOLERANCES:									
LINEAR:									
ANGULAR:									
	NAME	SIGNATURE	DATE						
DRAWN									
CHK'D									
APPV'D									
MFG									
Q.A									
						DWG NO.		A3	
						5.5 Gallon Pail - ChillerGlycol™ DF1 - 12" x 12" X 16" Box			
						WEIGHT:		SCALE:1:10	
								SHEET 1 OF 1	

PROPRIETARY NOTICE: DOCUMENT AND THE SUBJECT MATTER HEREOF ARE THE PROPERTY OF GLYCOL, INC. AND SHALL NOT BE REPRODUCED, COPIED, OR USED FOR THE PURPOSE OF MANUFACTURING OR SALE OF APPARATUS EXCEPT BY WRITTEN PERMISSION OF GLYCOL, INC.

